

## Fig. KUC16 Twin Spheres Rubber Flexible Connectors Installation & Maintenance Instructions

### PRODUCT LIFE CYCLE

The life of the joint is dependent on its application, frequency of use and freedom from misuse.

The properties of the fluid being transported such as pressure and temperature must be taken into account to avoid premature failure.

Before commissioning a system, it should be flushed to eliminate debris and chemically cleaned as appropriate to eliminate contamination, all of which will prolong the life of the joint.

### OPERATING PRESSURES AND TEMPERATURES

Maximum non shock pressure and temperature range:

Nylon reinforced EPDM liner - 16 bar from -10°C to 115°C

Water hammer and other shock conditions should be avoided.

Not suitable for fatigue loading, creep conditions, fire testing, fire hazard environment, corrosive service or transporting abrasive solids.

Movement of the pipework should be confirmed as the wrong selection may result in failure of the joint.

### PRESSURE / TEMPERATURE RATING

These flexible joints must be installed in a piping system where the normal pressure and temperature do not exceed the above ratings.

If system testing will subject the joints to pressures in excess of the working pressure rating, this should be within the test pressure for the rubber bellows.

If the limits of use specified in these instructions are exceeded or if used on applications for which it was not designed, a potential hazard could result.

### ANCHORING

The pipework should be anchored prior to system testing and to ensure correct performance of the rubber bellows.

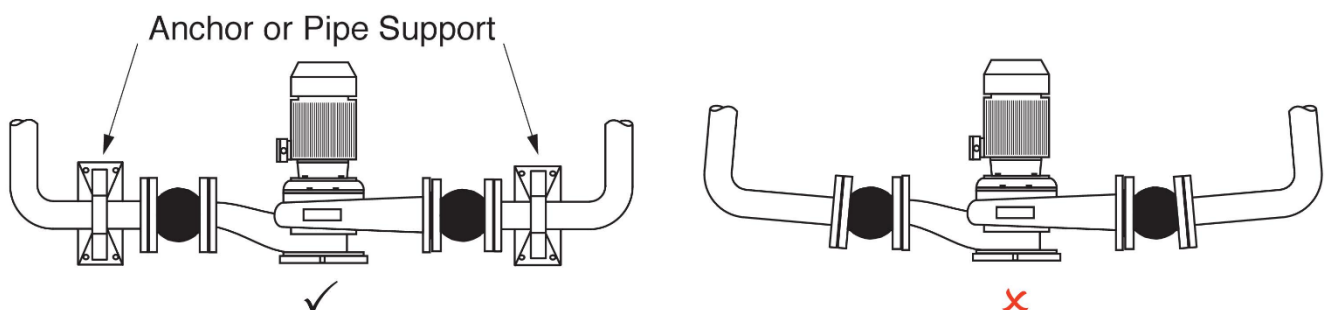

### STORAGE

Flexible joints contain a rubber bellows which should be stored in a cool, dark and clean area to prevent sunlight damage and general deterioration.

## Fig. KUC16 Twin Spheres Rubber Flexible Connectors Installation & Maintenance Instructions

### LAYOUT AND SITING

It should be considered at the design stage where joints will be located to give access for inspection and replacement.

### INSTALLATION

Flexible joints should be installed with the bellows at its relaxed length and pipework should be in-line and straight. The pipework should be adjusted if the dimensions and movement capabilities of the bellows are exceeded.

The union ends should be removed from the bellows and fitted to the pipework or pump allowing space for the relaxed bellows and 2 sealing washers.

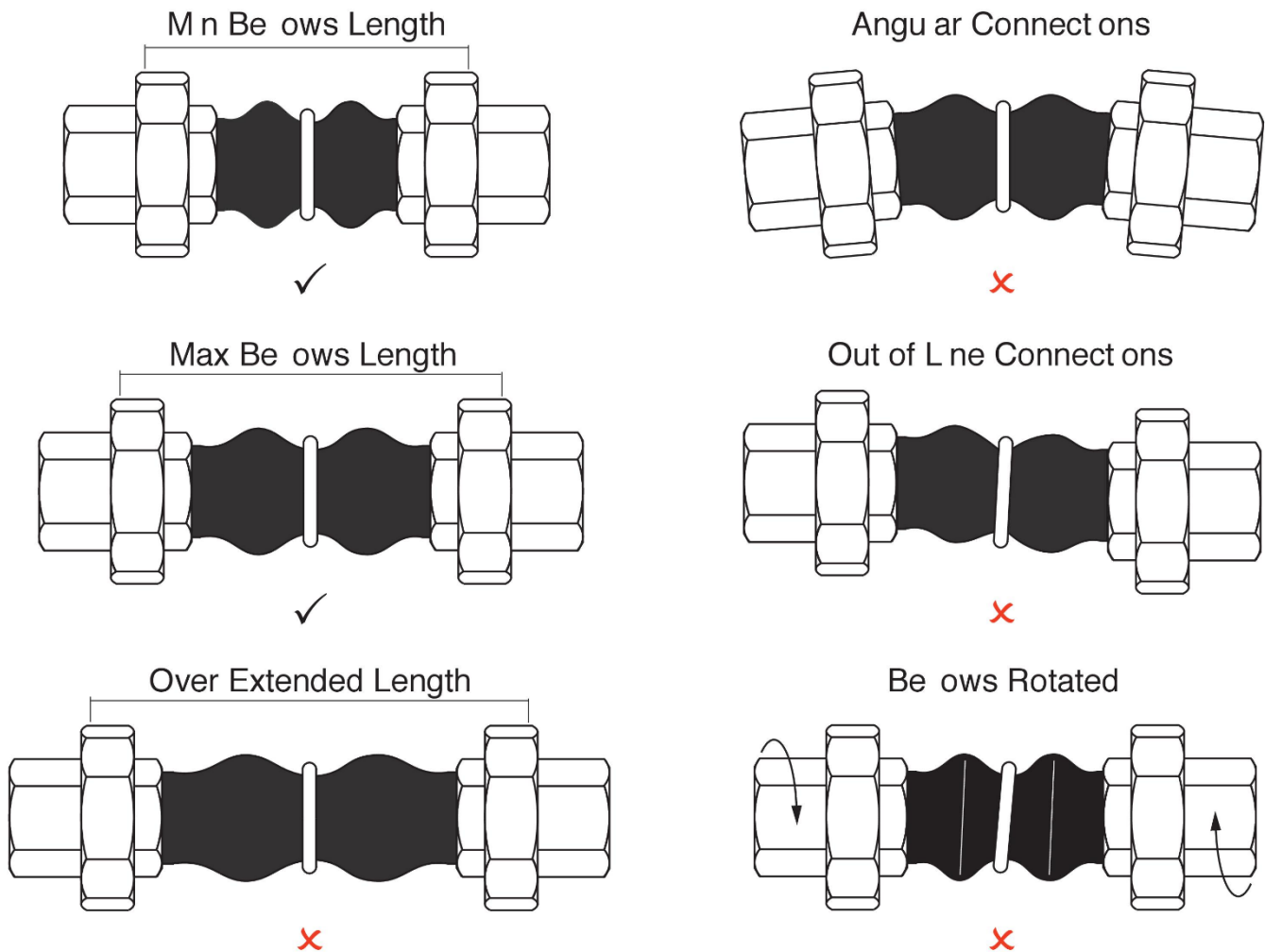

It is common practice to apply thread sealing compounds appropriate to the application but excessive use should be avoided, since this increases thread interference and may cause overstressing of the hexagon ends.

Screw the union nuts onto the bellows and hand tighten ensuring the bellows are not rotated or twisted.

---

## Fig. KUC16 Twin Spheres Rubber Flexible Connectors Installation & Maintenance Instructions

---

Correctly fitting spanners should be used on the union nut and hexagon on the ends of the bellows.

Using the hexagon and union nut tighten to make a water tight joint taking care not over compress the sealing washer, repeat the procedure for the second joint.

After 7 days check the union joints for leakage.

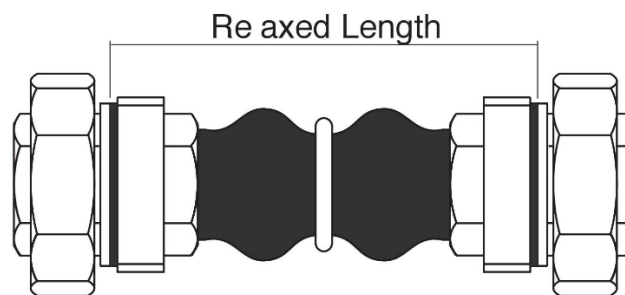

### MAINTENANCE

When selected and installed correctly flexible joints will give many years of trouble free service.

They should be periodically inspected for any signs of aging or if hairline cracks have appeared as this indicates the bellows is nearing the end of its service life and should be replaced.

If insulation is used it should be removed for inspection.

Rubber bellows should not be painted as this may cause the bellows to deteriorate.