

Fig. KIG16RS

Cast Iron Gate Valve

Rising Stem

BS5150 PN16

Notes:

- Designed to BS5150
- Pressure Rating: PN16
- Working Medium: Water, Oil, Steam
- Flanged to BS4504 / BS EN1092-2
- Outside screw & yoke, rising stem
- Face to Face: BS EN558-1
- Other flange standards available upon request
- Other PN pressure ratings available upon request
- ANSI standards available upon request.

Material Specifications

Description	Material
Body	Cast Iron
Body Seat Ring	Bronze
Wedge Seat Ring	Bronze
Wedge	Cast Iron
Stem	SS416
Bonnet	Cast Iron
Handwheel	Carbon Steel

Dimensions

DN	L	D1	D2	b	f	n-ød
65	190	145	185	20	3	4-ø 18
80	203	160	200	22	3	8-ø 18
100	229	180	220	24	3	8-ø 18
125	254	210	250	26	3	8-ø 18
150	267	240	285	26	3	8-ø 22
200	292	295	340	30	3	12-ø 22
250	330	355	405	32	3	12-ø 26
300	356	410	460	32	4	12-ø 26

All dimensions are nominal (indicative)
Actual dimensions may vary

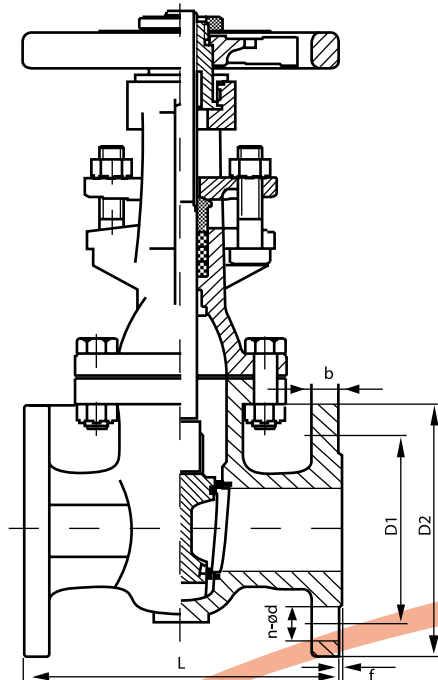

Fig. No. KIG16RS

