

Fig. KIG16

Cast Iron Gate Valve

Non-Rising Stem

BS5150 PN16

Notes:

- Designed to BS5150
- Pressure Rating: PN16
- Working Medium: Water, Oil, Steam
- Flanged to BS4504 / BS EN1092-2
- Rising stem available
- DI Body available upon request
- Other flange standards available upon request
- Other PN pressure ratings available upon request
- ANSI standards available upon request.

Material Specifications

Description	Material
Body	Cast Iron
Body Seat Ring	Cast Bronze
Wedge Seat Ring	Cast Bronze
Wedge	Cast Iron
Stem	Stainless Steel 416
Bonnet	Cast Iron
Handwheel	Cast Iron

Dimensions

DN	L	D	D1	D2	b	f	n-ød
350	381	429	470	533	36	4	16-ø28
400	406	480	525	597	38	4	16-ø31
450	432	548	585	635	40	4	20-ø31
500	457	609	650	715	42	4	20-ø34
600	508	720	770	840	48	5	20-ø37

All dimensions are nominal (indicative)
Actual dimensions may vary

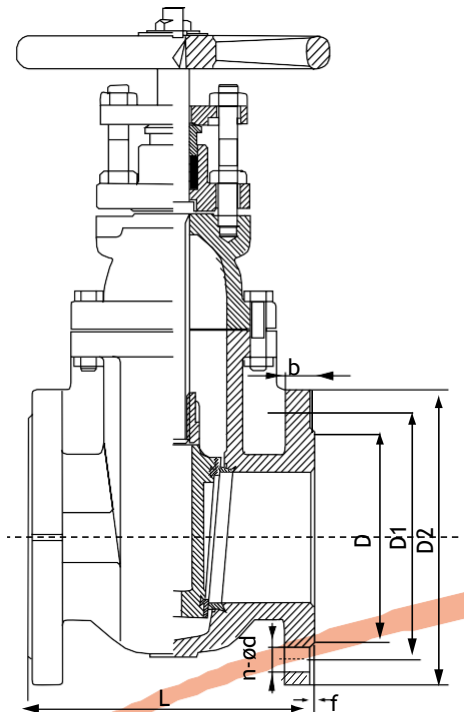

Fig. No. KIG16

